

HYDRANT LANDING VALVE

HYD-090

HYDRANT LANDING VALVE 90 DEGREES



DETAILS

- Approvals Watermark Certificate to AS 24192
- Licence number WMKA21817
- Material C83600 AS 1565
- Approve AS 4020 contamination of water
- Approve AS 2345 dezincification test
- Flow rate 10L/s when pressure $\geq 25\text{kPa}$
- Sealing torque $\leq 40\text{Nm}$ when pressure 21 bar
- Body test & seat test 27bar (2700kPa)
- Pressure retention test 32bar (3200kPa)
- Temperature Rating $-10^{\circ}\text{C} \sim 85^{\circ}\text{C}$
- Wall thickness $\geq 3\text{mm}$. Inlet roll grooved wall thickness $\geq 5.4\text{mm}$.
- Storz fitting on landing valve complies with NEN3374 1971



***ALSO AVAILABLE IN NON-LOCTITE STORZ FOR NSW. (PRODUCT CODE: HYD-NSW)**

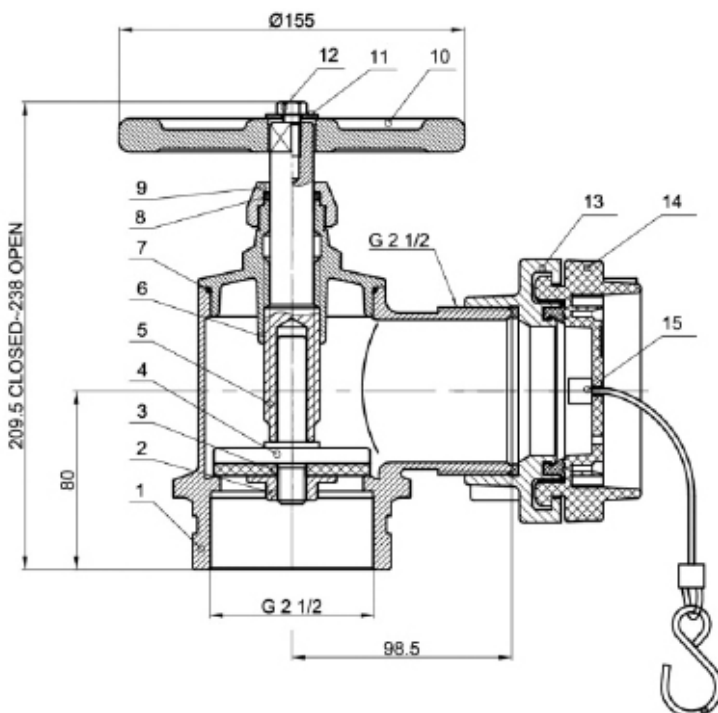

MATERIAL LIST

NO.	PART
01	BODY
02	NUT
03	WASHER
04	SEAT
05	SPINDLE
06	COVER
07	O-RING
08	O-RING
09	COVER NUT
10	WHEEL HANDLE
11	WASHER
12	HEX BOLT
13	STORZ SUB-ASSY
14	PLUG
15	CHAIN