

300PSI FLANGED END SWING CHECK VALVES

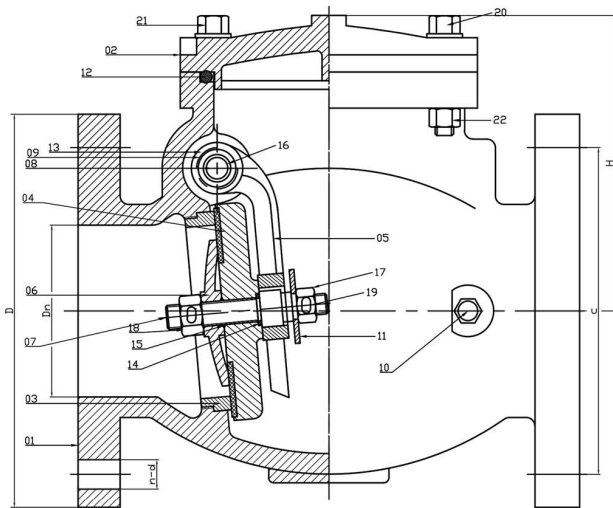

FCV-100 → FCV-200

SWING CHECK VALVE



MATERIAL LIST

| PART | SPECIFICATION |
|--|--------------------|
| 1 BODY | ASTM A536 65-45-12 |
| 2 BONNET | ASTM A536 65-45-12 |
| 3 SEAT RING | ASTM A148 C95400 |
| 4 DISC | ASTM A536 65-45-12 |
| 5 ROCKER ARM | ASTM A536 65-45-12 |
| 6 BAFFLE PLATE | ASTM A148 C95400 |
| 7 MIDDLE PLATE | ASTM A276 SS304 |
| 8 PINNED STEM | ASTM A276 SS304 |
| 9 BRACKET SCREW | ASTM A351 SS304 |
| 10 PLUG | ASTM A148 C95400 |
| 11 GASKET | ASTM A276 SS304 |
| 12 O-RING (LARGE) | ASTM D2000 EPDM |
| 13 O-RING (FOR BRACKET SCREW) | ASTM D2000 EPDM |
| 14 O-RING (FOR MID STEM) | ASTM D2000 EPDM |
| 15 O-RING (FOR MID STEM SMALL) | ASTM D2000 EPDM |
| 16 BRONZE BUSHING | POWDER METALLURGY |
| 17 SS304 OUTER HEXAGON NUT M12 | ASTM A276 SS304 |
| 18 SS304 OUTER HEXAGON NUT M12 | ASTM A276 SS304 |
| 19 SS304 COTTER PIN 4X55 | ASTM A276 SS304 |
| 20 "M 12X60 ZINC OUTER HEXAGON BOLT (HALF THREAD)" | ASTM A194 2H STEEL |
| 21 "M 12X60 ZINC OUTER HEXAGON BOLT (FULL THREAD)" | ASTM A194 2H STEEL |
| 22 M12 ZINC OUTER HEXAGON NUT | ASTM A194 2H STEEL |

DIMENSION - WEIGHTS - QUANTITIES

| SIZE | Dn | L | D | c | n-d | H |
|------|-----|-----|-----|-------|-------|-----|
| 4" | 100 | 292 | 229 | 190.5 | 8-ø19 | 172 |
| 6" | 152 | 356 | 279 | 241.5 | 8-ø22 | 233 |
| 8" | 204 | 495 | 343 | 298.5 | 8-ø22 | 301 |

- DESIGN STANDARD: AWWA C508
- NOMINAL PRESSURE: 300PSI
- FLANGE STANDARD: ASME/ANSI B16.1 CLASS 125 OR ASME/ANSI B16.42 CLASS 150 OR BS EN 1092-2 PN16 OR GB/T9113.1
- EPOXY RESIN COATING BOTH INSIDE AND OUTSIDE THE BODY
- TABLE E DRILLING