

300PSI FLANGED END SWING CHECK VALVES

FCV-100 → FCV-200

SWING CHECK VALVE

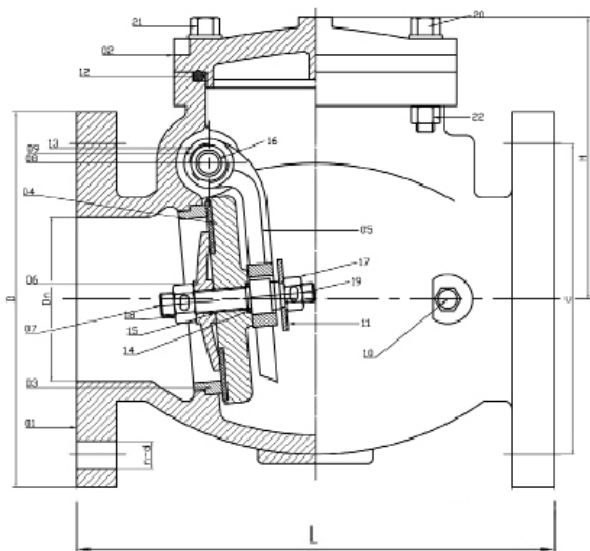

MATERIAL LIST

PART	SPECIFICATION
1 BODY	ASTM A536 65-45-12
2 BONNET	ASTM A536 65-45-12
3 SEAT RING	ASTM A148 C95400
4 DISC	ASTM A536 65-45-12
5 ROCKER ARM	ASTM A536 65-45-12
6 BAFFLE PLATE	ASTM A148 C95400
7 MIDDLE PLATE	ASTM A276 SS304
8 PINNED STEM	ASTM A276 SS304
9 BRACKET SCREW	ASTM A351 SS304
10 PLUG	ASTM A148 C95400
11 GASKET	ASTM A276 SS304
12 O-RING (LARGE)	ASTM D2000 EPDM
13 O-RING (FOR BRACKET SCREW)	ASTM D2000 EPDM
14 O-RING (FOR MID STEM)	ASTM D2000 EPDM
15 O-RING (FOR MID STEM SMALL)	ASTM D2000 EPDM
16 BRONZE BUSHING	POWDER METALLURGY
17 SS304 OUTER HEXAGON NUT M12	ASTM A276 SS304
18 SS304 OUTER HEXAGON NUT M12	ASTM A276 SS304
19 SS304 COTTER PIN 4X55	ASTM A276 SS304
20 "M12X60 ZINC OUTER HEXAGON BOLT (HALF THREAD)"	ASTM A194 2H STEEL
21 "M12X60 ZINC OUTER HEXAGON BOLT (FULL THREAD)"	ASTM A194 2H STEEL
22 M12 ZINC OUTER HEXAGON NUT	ASTM A194 2H STEEL

DIMENSION - WEIGHTS - QUANTITIES

SIZE	Dn	L	D	c	n-d	H
4"	100	292	229	190.5	8-ø19	172
6"	152	356	279	241.5	8-ø22	233
8"	204	495	343	298.5	8-ø22	301

- DESIGN STANDARD: AWWA C508
- NOMINAL PRESSURE: 300PSI
- FLANGE STANDARD: ASME/ANSI B16.1 CLASS 125 OR ASME/ANSI B16.42 CLASS 150 OR BS EN 1092-2 PN16 OR GB/T9113.1
- EPOXY RESIN COATING BOTH INSIDE AND OUTSIDE THE BODY
- TABLE E DRILLING