

HYDRANT LANDING VALVE

HYD -090

HYDRANT LANDING VALVE 90Deg



DETAILS

Standards mark Certificate No. SMK21817

AS 2419.2 Material C83600 AS 1565

AS2345 dezincification test Flow

rate 10L/s when pressure $\geq 25\text{kPa}$

Sealing torque $< 40\text{Nm}$ when pressure 21 bar

Body test & seat test 27bar

(2700kPa) Pressure retention

test 32bar (3200kPa)

Temperature Rate $-10^{\circ}\text{C} - 85^{\circ}\text{C}$

Wall thickness $\geq 3\text{mm}$. Inlet roll grooved wall thickness $\geq 5.4\text{mm}$.

Storz fitting on landing valve complies with NEN3374 1971



*ALSO AVAILABLE IN NON-LOCTITE STORZ FOR NSW. (PRODUCT CODE: HYD-NSW)

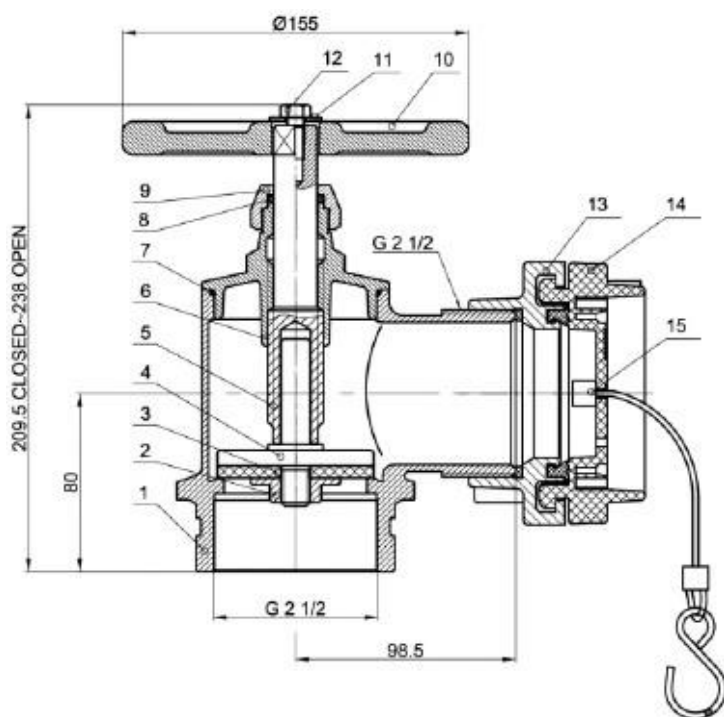

MATERIAL LIST

NO.	PART
01	BODY
02	NUT
03	WASHER
04	SEAT
05	SPINDLE
06	COVER
07	O-RING
08	O-RING
09	COVER NUT
10	WHEEL HANDLE
11	WASHER
12	HEX BOLT
13	STORZ SUB-ASSY
14	PLUG
15	CHAIN