

Stainless Steel Hydrant

HYD -ZT2

Stainless Steel Hydrant Valve 90° "Loctite"

80mm Roll Groove with 65mm Threaded BSP



Details

Certified AMI74819 Standard AS 2419.2:2009 Material

Approve AS 2345 dezincification test

Flow rate 10L/s when pressure 25kPa

Sealing torque 40Nm when pressure 21 bar

Body test & seat test 27bar (2700kPa)

Pressure retention test 32bar (3200kPa)

Temperature Rating -10°C ~ 85°C Wall thickness 3mm. Inlet roll grooved wall thickness 5.4mm

Forged Storz fitting on landing valve complies with NEN3374

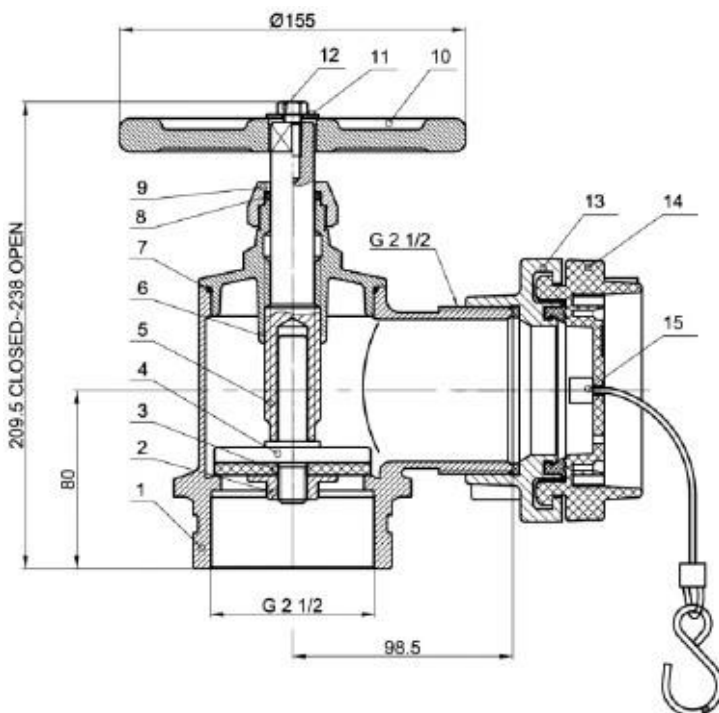

Part		
01	Hand Wheel	HT200
02	Bonnet nut	CF8(304)
03	bonnet	CF8(304)
04	Stem	316/431
05	Disc	CF8(304)
06	Seal Gasket	NBR/EPDM
07	Seal Nut	CF8(304)
08	Body	CF8(304)
09	Hand wheel Nut	201
10	Flat Gasket	201
11	Stem Sealing	NBR/EPDM
12	Bonnet Sealing	NBR/EPDM
13	Storz Sealing1	NBR
14	Storz Sealing 2	NBR
15	Storz	Al alloy
16	Plug	PA6
17	S-Hook + Cable	SS